

## 性能特点 Performance Feature

### 1. 指示器 Indicator

指示器符合VID/VIE3845 NAMUR标准，便于安装限位开关、定位器等附件。

The indicator conforms to the VID/VIE3845 NAMUR standard, which is convenient for installing limit switch, positioner and other accessories.

### 2. 输出轴 Output Shaft

镀镍合金钢一体式锻压输出轴的设计符合NAMUR、ISO5211、DIN3337标准。特殊标准可根据客户要求去定制。

The design of the one-body forging and pressing output shaft of nickel-plated alloy steel is in accordance with NAMUR, ISO5211 and DIN3337 standard. Special standards can be customized according to the customer.

### 3. 缸体 Cylinder Block

由优质铝合金挤压成形，表面进行硬质阳极氧化处理、特氟龙涂层。

It is made of high quality aluminum alloy extrusion, the surface is coated with hard anodic oxidation and teflon coating.

### 4. 端盖 End Cover

铝合金压铸，表面阳极硬化处理、金属聚酯涂层。

Aluminum alloy die casting, surface with anodic hardening treatment and metal polyester coating.

### 5. 活塞 Piston

采用铸铝硬质氧化处理

Cast aluminum with hard oxidation.

### 6. 调节螺栓 Adjustment Bolt

两个独立行程调节螺栓可以方便精确的在 $\pm 5^\circ$ 以内调整阀门的开合角度。

Two independent adjustment bolts realizes accurate adjustment within  $\pm 5^\circ$  of the angle of the valve opening and closing.

### 7. 活塞环 Piston Ring

采用低摩擦、长寿命复合材料，维修更换方便。

Use low friction and long life composite material, convenient repair and replace.

### 8. 密封 Seal

常温下使用丁腈橡胶，高温和低温工况下，根据客户要求使用特殊的密封。

Use nitrile rubber under normal temperature, special seal is available according to the customer's requirement for high temperature and low temperature.

### 9. 气源接口 Air Connection

符合NAMUR标准，可直接安装NAMUR标准电磁阀。

It complies with NAMUR standard and can be directly mounted with NAMUR standard solenoid valve.

### 10. 所有紧固件均采用不锈钢材料。

符合NAMUR标准，可直接安装NAMUR标准电磁阀。

All fasteners are made of stainless steel.

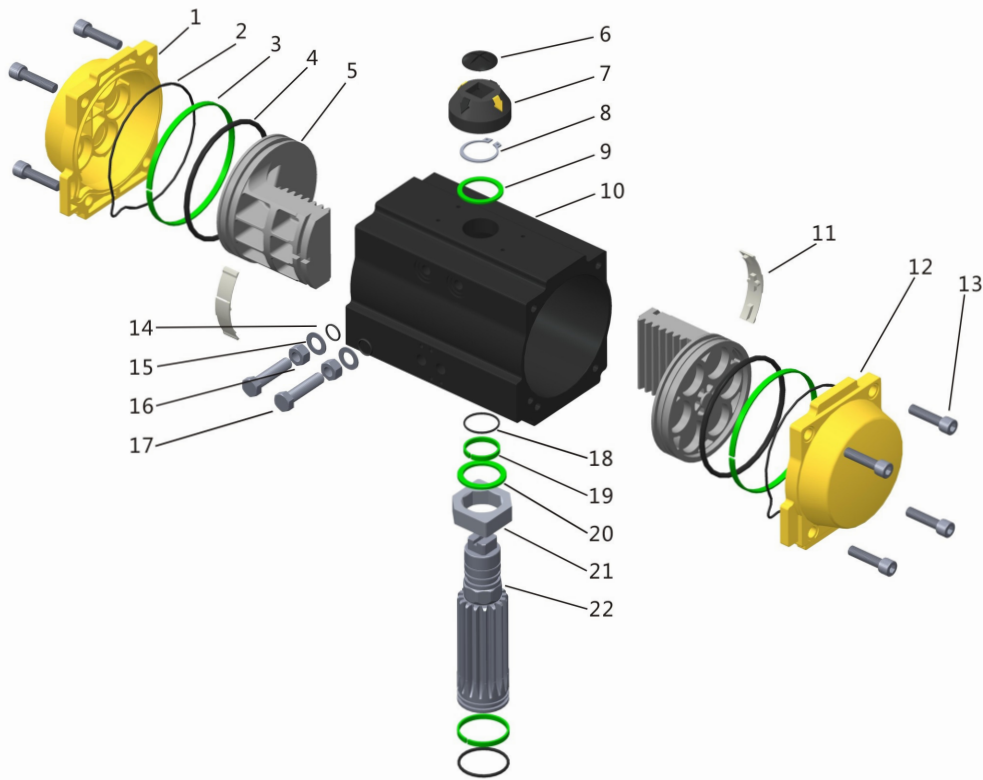

## ▲ 零部件明细表 Components Material

序号 NO	名称 Name	单台数量 Qty for Each Unit	标准材料 Standard Material	可选材料 Materials Selectable
1	左端盖 Left Cover	1	压铸铝合金 Aluminum Die Casting	
2	O型圈 (端盖) "O" Ring (cover)	2	丁腈橡胶 NBR	氟橡胶硅橡胶 FPM/Q
3	活塞环 piston ring	2	POM	
4	O型圈 (活塞) "O" Ring (piston)	2	丁腈橡胶 NBR	氟橡胶硅橡胶 FPM/Q
5	活塞 Piston	2	压铸铝合金 Aluminum Die Casting	
6	螺钉 Bolt	1	ABS	
7	指示器主体 Main Body of the Indicator	1	ABS	
8	轴用挡圈 Shaft Ring	1	不锈钢 Stainless Steel	
9	垫片 Gasket	1	POM	
10	缸体 Block	1	挤压铝合金 Aluminum Extrusion	
11	导向环 Guide Ring	2	PA66	
12	右端盖 Right Cover	1	压铸铝合金 Aluminum Die Casting	
13	端盖螺栓 End Cover Bolt	8	不锈钢 Stainless Steel	
14	O型圈 (调节螺栓) "O" Ring (adjusting bolt)	2	丁腈橡胶 NBR	氟橡胶硅橡胶 FPM/Q
15	垫片 Gasket	2	不锈钢 Stainless Steel	
16	螺母 Nut	2	不锈钢 Stainless Steel	
17	调节螺栓 Adjustment Bolt	2	不锈钢 Stainless Steel	
18	O型圈 (轴上) "O" Ring (at the top of the shaft)	1	丁腈橡胶 NBR	氟橡胶硅橡胶 FPM/Q
19	轴承 (轴上) Bearing (at the top of the shaft)	1	POM	
20	垫片 Gasket	1	POM	
21	调节凸轮 Adjustment Cam	1	碳钢 Carbonsteel	
22	输出轴 Output Shaft	1	碳钢 Carbonsteel	
23	轴承 (轴下) Bearing (output shaft bottom)	1	POM	
24	O型圈 (轴下) "O" Ring (output shaft bottom)	1	丁腈橡胶 NBR	氟橡胶硅橡胶 FPM/Q

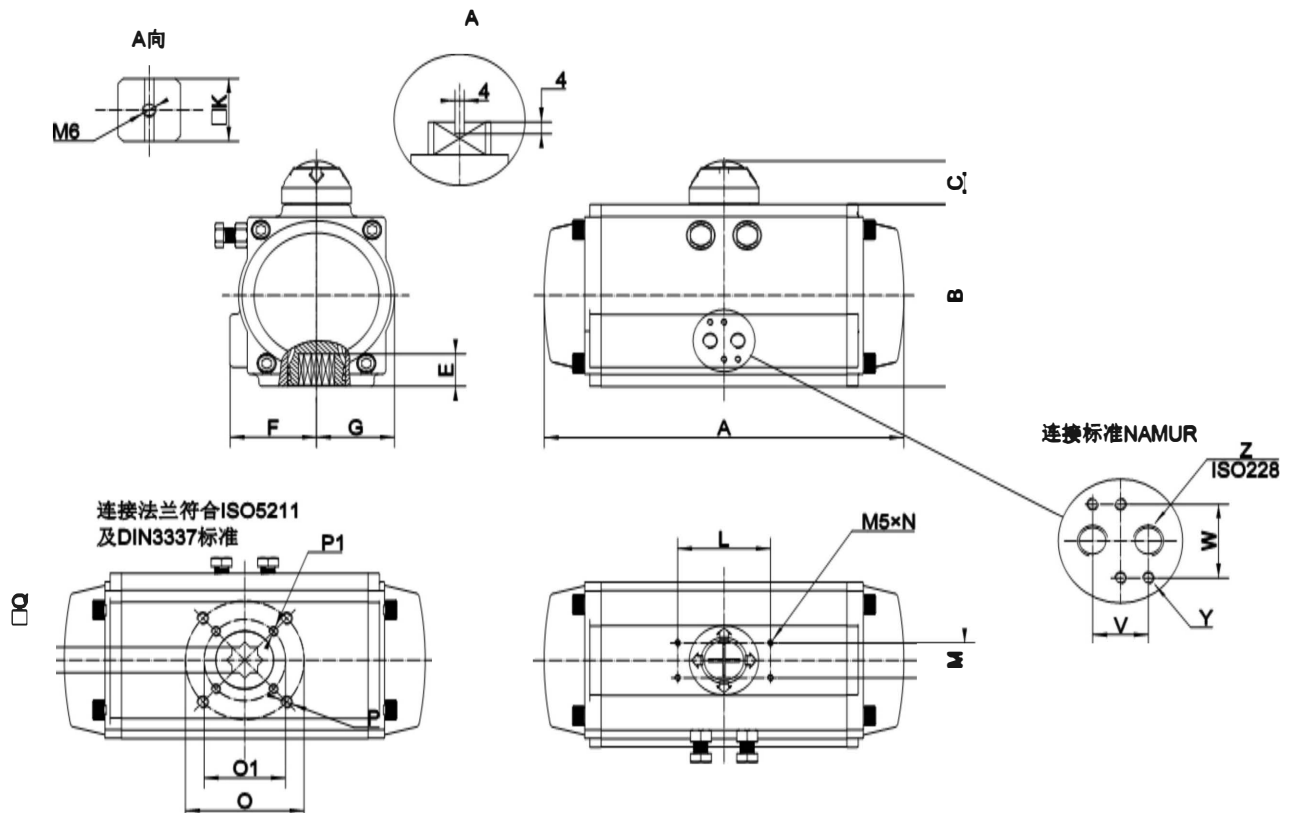

## 外形及连接尺寸 Dimensions and Connection(mm)

型号Model	RT052	RT063	RT075	RT083	RT092	RT105	RT125	RT140	RT160	RT190	RT210	RT240	RT270	RT300	RT350	RT400
ISO flange	F03/F05	F05/F07	F05/F07	F05/F07	F07/F10	F07/F10	F07/F10	F10/F12	F10/F12	F14	F14	F16	F16	F16	F16/F25	F16/F25
A	154	176	188	211	244	277	310	394	458	523	526	602	718	760	920	940
B	73	89	101	110	118	135	157	175	198	232	257	289	326	350	410	466
C	25	25	25	25	25	25	39	39	39	39	39	30	30	30	30	30
E	13	17	17	20	20	25	27	30	30	38	38	50	50	50	50	50
F	41	47	53	57	60	64	75	75	86	103	113	130	147	174	195	260
G	30	36	43	47	50	58	67	75	86	103	113	130	147	162	190	260
L	80	80	80	80	80	80	80	130	130	130	130	130	130	130	130	130
M	30	30	30	30	30	30	30	30	30	30	30	30	30	30	30	30
N	4-M5x9	4-M5x9	4-M5x9	4-M5x9	4-M5x9	4-M5x9	4-M5x9	4-M5x9	4-M5x9	4-M5x9	4-M5x9	4-M5x9	4-M5x9	4-M5x9	4-M5x9	4-M5x9
O	50	70	70	70	102	102	102	125	125	140	140	165	165	165	254	254
P	4-M6x9	4-M8x12	4-M8x12	4-M8x12	4-M10x15	4-M10x15	4-M10x15	4-M12x18	4-M12x18	4-M16x24	4-M16x24	4-M20x25	4-M20x25	4-M20x25	8-M16x25	8-M16x25
O1	36	50	50	50	70	70	70	102	102						165	165
P1	4-M5x8	4-M6x9	4-M6x9	4-M6x9	4-M8x12	4-M8x12	4-M8x12	4-M10x15	4-M10x15						4-M20x25	4-M20x25
Q	11	14	14	17	17	22	22	27	27	36	36	46	46	46	46	46
V	24	24	24	24	24	24	24	24	24	24	24	24	40	40	40	40
W	36	36	36	36	36	36	36	36	36	36	36	36	45	45	45	45
Y	4-M5x9	4-M5x9	4-M5x9	4-M5x9	4-M5x9	4-M5x9	4-M5x9	4-M5x9	4-M5x9	4-M5x9	4-M5x9	4-M5x9	4-M6x10	4-M6x10	4-M6x10	4-M6x10
Z	G1/4"	G1/4"	G1/4"	G1/4"	G1/4"	G1/4"	G1/4"	G1/4"	G1/4"	G1/4"	G1/4"	G1/4"	G1/2"	G1/2"	G1/2"	G1/2"

# 输出扭矩 Output Torque

## 双作用式输出扭矩 Double Acting Output Torque(Nm)

执行器型号 Actuator Model	2.0Bar	2.5Bar	3.0Bar	4.0Bar	4.5Bar	5.0bar	5.5bar	6.0bar	7.0bar	8.0bar
RT052D	8	10	12	16	18	20	22	24	28	32
RT063D	15	18	22	29	33	36	40	44	51	58
RT075D	20	25	30	40	45	50	55	60	70	80
RT083D	31	39	47	63	70	78	86	94	111	125
RT092D	45	56	68	90	102	113	124	135	158	181
RT105D	66	83	99	132	149	165	182	198	231	264
RT125D	100	125	150	200	226	251	276	301	351	401
RT140D	171	214	256	342	385	427	470	513	598	684
RT160D	266	332	399	532	598	665	731	798	931	1064
RT190D	420	532	638	851	958	1064	1170	1277	1490	1702
RT210D	532	665	798	1064	1197	1330	1463	1596	1862	2128
RT240D	769	962	1154	1539	1731	1924	2116	2308	2693	3078
RT270D	1170	1462	1750	2339	2632	2924	3216	3509	4094	4679
RT300D	1526	1908	2289	3052	3434	3815	4197	4578	5341	6104
RT350D	2285	2856	3427	4570	5141	5712	6283	6854	7997	9139
RT400D	3256	4070	4884	6512	7326	8140	8954	9768	11396	13024

## 单作用式输出扭矩 (弹簧复位) Single Action Output Torque(Spring Return)(Nm)

执行器 型号 Actuator Model	弹簧 数量 Spring Quantity	空气压力扭矩 Air Pressure Torque											
		4Bar		5.0Bar		6.0Bar		7.0Bar		8.0Bar		弹簧复位扭矩 Spring Return Torque	
		0° 开始 Start	90° 结束 End	0° 开始 Start	90° 结束 End	0° 开始 Start	90° 结束 End	0° 开始 Start	90° 结束 End	0° 开始 Start	90° 结束 End	0° 开始 Start	90° 结束 End
RT052S	10	7.4	3.6	11.5	6.7	15.5	11.6	19.5	15.6	/	/	12.4	8.5
RT063S	10	1.4	8.2	22.8	15.6	30	22.8	37.3	30.1	44.7	37.4	20.9	13.7
RT075S	10	19	11.1	28.8	21.2	39	31.2	49.1	41.2	59.1	51.2	29	21.1
RT083S	10	31	16.6	46.7	32.3	62.4	48	78.1	63.7	93.8	79.3	46	31.6
RT092S	10	43.6	21.5	66.2	44.1	88.8	66.7	111.3	89.2	134	11.8	68.7	46.7
RT105S	10	68.9	33.4	102	66.5	135.1	99.6	161.8	123.1	201.2	165.7	98.4	63.3
RT125S	10	96	44	146	94	196	144	247	194	297	245	157	105
RT140S	10	170	84	256	169	314	255	427	340	512	426	258	172
RT160S	10	253	115	386	248	519	381	652	514	785	647	417	279
RT190S	10	451	233	664	446	877	658	1090	871	1302	1084	618	400
RT210S	10	514	304	780	570	1046	836	1312	1102	1578	1368	760	550
RT240S	10	718	431	1103	816	1488	1201	1872	1586	2257	1970	1108	821
RT270S	10	1220	767	1805	1352	2390	1937	2974	2521	3560	3107	1572	1119
RT300S	10	1430	695	2355	1693	2956	2221	3719	2984	4482	3747	2122	1460
RT350S	10	1963	787	3105	1929	4247	3071	5390	4214	6532	5356	3405	2346
RT400S	10	3012	1025	4640	2653	6268	4281	7895	5908	9523	7536	4938	3149